



LOW-E HOUSEWRAP
Reduces your carbon footprint



Low-E HouseWrap™ Tech Manual

ESP Inc
313 W Golden Lane
New Oxford, PA 17350
1-800-289-5693
www.low-e.com

Table of Contents

Testing Requirements & Overview	1
MSDS	2
ICC- ES Evaluation Report ESR-3079	3-4
NFPA 286 Test.....	5-6
2009 IECC (Residential Energy Efficiency)	7-9
Evaluation of Thermal Resistance(R-15, Low-E Housewrap, Vinyl Siding	10
Evaluation of Thermal Resistance(R-15, Low-E Housewrap, Brick	11-12
Evaluation of Thermal Resistance(R-15, Low-E Housewrap, Stone	13-14
ESP Low-E HouseWrap Install Guide	15-19

General Information

ESP Low-E® Housewrap is the trade name for ESP Inc's perforated reflective insulation product. ESP Low-E® Housewrap products are not to be used where a perm rating requirement is less than 1.0. ESP Inc. manufactures other products that do act as vapor barriers. ESP Inc. does not determine where the vapor barrier is required in a wall system. Please consult your local codes for proper placement of vapor barriers.

Before You Proceed

The best time to install ESP Low-E® Housewrap is:

After walls have been constructed

After sheathing has been installed

After flashing details have been installed

Before the doors and windows have been set inside framed openings

Prior to installation of primary wall covering

Additional Information

As with any weather resistant barrier ESP Low-E® Housewrap is not intended to be used as the primary barrier for the structure. It is important to coordinate the installation of the primary barrier in a timely manner.

Specifications & Data

Low-E Housewrap™ Product Information

Product Identification:

Product Name:Low-E Housewrap™ Insulation

Product Codes:4PFNS, 5PFNT, 6PFNS

Other Information:

Finished Dimension:48" Width x 125' Length(Standard)

60" Width x 100' Length

72" Width x 100' Length

Additional Lengths Available Upon Request(smaller lengths must be approved by ESP).

Core Material: Polyethylene

Facing: 99.4% Polished Aluminum non reinforced one side

NFPA 286 Walls Only: Passed

Notes and Warnings:

DO NOT install with foam exposed. ESP Low-E® Housewrap is meant to be used on and exterior wall.

Please consult ESP Inc. prior to any deviation from intended use

Warning: Although ESP Low-E® Insulation Products are all ASTM fire tested, it is recommended that they or any insulation material should not be exposed to open flame or other ignition sources of sufficient intensity during shipment, storage or installation.

Caution: Aluminum is an electrical conductor. Please use caution when working around electrical sources including overhead power lines.

Testing Overview and Results

Test Description	Test Requirements	Test Results	Page References
Perm Test ASTM E-96	ESR-3079	ESR-3079	Page 3
Water Resistance ASTM D-779	ESR-3079	ESR-3079	Page 3
Ultraviolet light	ESR-3079	ESR-3079	Page 3
Accelerated Aging	ESR-3079	ESR-3079	Page 3
Tensile Strength	ESR-3079	ESR-3079	Page 3
NFPA 286 Walls	NFPA 286	PASSED	Page 5
U-value Wall (zone 5-7) 2009 IECC	Max .057	.056 vinyl	Page 8
U-value Wall (zone 5-7) 2009 IECC	Max .057	.051 brick	Page 9
U-value Wall (zone 5-7) 2009 IECC	Max .057	.063 Stone	Page 11

The system U-values described in The Evaluation of Thermal Resistance of a Building Envelope Assembly demonstrates the performance of wood framed walls (2 x 4 construction 16" on center). The U-value calculations are based on methods outlined by the ASHRAE Handbook of Fundamentals. The U-value performance of these systems achieve a U-value between .051 (brick), .056 (vinyl) and .063 (stone) satisfying or exceeding requirements for zones 1-7 established by 2009 IECC Code Table 402.1.3 or equivalent UA alternative values established by other code bodies. To obtain building envelope compliance input respective U-values for areas representing its wall design into compliance software. For more information regarding UA evaluation and/or compliance criteria contact ESP at 800-289-5693

MANUFACTURER'S WARNING: ESP Low-E® Housewrap is intended for use on exterior walls under primary barrier.

ASTM standard test method for surface burning characteristics of building materials: This standard is used to measure and describe the response of materials, products, or assemblies to heat and flame under controlled laboratory conditions. ESP Low-E® Housewrap is tested within the strict standard of this test method. This test method is not necessarily representative of the manner in which the ESP Low-E® Housewrap is installed in a typical field installation. The numerical ratings on all ESP Low-E Housewrap products or any other materials are not intended to reflect hazards under actual fire conditions.

Warning: Aluminum is an Electrical Conductor. Please use caution when working around electrical sources including overhead power lines.

NOTE: Rolls of insulation shall be packaged in a polyethylene wrapping. Insulation shall be stored in a protected area. Do not allow insulation to come in contact with fresh concrete at any time. Any tears or punctures in the foil shall be repaired with aluminum tape. All seams that require taping must be taped with aluminum tape.



LOW-E HOUSEWRAP
Reduces your carbon footprint

Environmentally Safe Products, Inc.
313 West Golden Lane
New Oxford, PA 17350
1-717-624-3581

PRODUCT IDENTIFICATION

Product Name , Low-E HouseWrap™ Code# 5PFNT
4PFNS

Other Product Identifiers: Code #'s
Contact for further information: Thomas M. Miller

CHEMICAL & PHYSICAL PROPERTIES

Color: Aluminum, White
Physical State: Solid
Boiling Point: N/A
Freezing Point: N/A
Vapor Density: Not Volatile
Melt Point (foam): 106°C
Product Type: Foil / Polyethylene foam / Polyethylene film
Odor: None
Specific Gravity (foam): 0.02 - 0.04
Bulk density: 1.0 - 1.2 lb./cu. Ft.
Percent Volatile: Nil
Hazardous Ingredient: None
Family / Chemical name: Plastic / Aluminum / Polyethylene
Flammable Limits: N/A
Decomposition / Combustion Products: Thermal decomposition may include carbon monoxide, carbon dioxide, aldehydes and organic vapors.

FIRE PROTECTION INFORMATION

Flash point (foam core): Above 450°F
Recommended extinguishing media: CO₂, water, Dry Chemical, Foam
Polymerization: Will not occur
Stability: Stable
Toxic products which may form: No toxicity, safe physical form

STORAGE AND REACTIVITY

Storage Conditions: Store large quantities in area protected by automatic sprinklers

TRANSPORTATION

Hazard classes: None - not hazardous
Hazard labels: None required
Hazard determination: Material safety data
Size shipping container: Varies according to product ordered

HEALTH HAZARD DATA

Short term exposure

Route of entry: Precautionary treatment
Inhalation: N/A
Skin: Wash affected area with soap and water
Eyes: N/A
Ingestion: Contact poison control data

Long term exposure

Carcinogen: None
Target organ effects: None
Other health hazards: None known

PERSONNEL PROTECTION

Respiratory Protection: None required
Protective clothing: None required
Other protective measures: None

SPILL OR LEAK PROTECTION

Steps to be taken: N/A
Other impacts on wastewater treatment: None
Recommended wastewater treatment: N/A

RECOMMENDED WASTE DISPOSAL METHOD

Unused material: Reuse, if possible. If unavailable, incinerate or dispose of in government approved solid waste landfill

CONTAINER LABELING

Container disposal: N/A
Hazardous disposal: N/A
Explanation of unique labeling system: None used

Product Guarantee

Low-E Insulation products are guaranteed against defects in material and workmanship for 20 years. Blister or bubbles in product surface will not affect performance. Product thickness for products with foil on both sides may vary +/- 10%. All other products may vary +/- 20%.

Defective Material

The following criteria may be considered a defect;
(1.) 1 inch wide or more of foil delamination on the edges for more than 15 feet of the roll.
(2.) More than 1 inch of foam showing on 20 feet or more of a roll.
(3.) Large areas (more than 1 square foot) of delaminated foil.

Corrective Instructions

Occasionally there may be imperfections in product that may affect appearance but not performance. In the event this is encountered, the following solutions are advised;

- (1.) If there is foam showing on one side, either tape the seam on that side when installed or install product with the foam side in.
- (2.) If there is an edge that is delaminated, either tape the seam on that side when installed or install product with delaminated edge in.
- (3.) If there are areas that have a delamination that cannot be installed without correcting this defect, the following may be done with an iron; set the iron about half to three quarters temperature setting. Make a small slit with a razor knife in the center of the delamination and carefully, with light pressure, iron the foil towards the slit, allowing trapped air to escape. When finished, cover the slit with a small piece of Low-E tape.

Return Policy

- (1.) It is our opinion that our Distributors should handle customer problems directly and ESP in turn will issue a credit or replace materials to the Distributor. The Distributor must make available to ESP a copy of the product label or the information on the label [lot#, initials, product description], samples of the defect, or the roll of material. Upon inspection of the defect, ESP will credit or replace defective material at ESP's discretion. If a section of a roll is bad, remove the bad area and use the rest of the roll. Retain the bad section and label information for credit. If label is not available, return the bad section.
- (2.) All labels on the product must be saved for verification. If label is not sent back with completely filled out complaint form, the complaint will not be acknowledged. If everything is in order on the complaint form and sheets and ESP requests the return of the roll, ESP will pay the shipping, however no material is to be returned without ESP approval.
- (3.) If the customer elects to keep all the product that is considered seconds, and the complaint forms and labels are sent back, ESP will credit the customer for the difference in first quality and second quality pricing.
- (4.) If the product is shipped out of the continental United States, the representative is totally responsible for all replacement costs and shipping charges of the material.

ABSOLUTELY NO SHIPPING CHARGES WILL BE ACCEPTED WITHOUT APPROVAL FROM ESP

ASTM STANDARD TEST METHOD FOR SURFACE BURNING CHARACTERISTICS OF BUILDING MATERIALS: This standard is used to measure and describe the response of materials, products, or assemblies to heat and flame under controlled laboratory conditions. ESP Low-E® products are tested within the strict standard of this test method. This test method is not necessarily representative of the manner in which the ESP Low-E® products are installed in a typical field installation. The numerical ratings on all ESP Low-E® insulation products or any other materials are not intended to reflect hazards under actual fire conditions.

Warning:

Aluminum is an Electrical Conductor. Please use caution when working around electrical sources including overhead power lines.

ICC-ES Evaluation Report

ESR-3079

Issued May 1, 2010

*This report is subject to re-examination in one year***www.icc-es.org | (800) 423-6587 | (562-699-0543*****A Subsidiary of the International Code Council®*****DIVISION: 07-THERMAL AND MOISTURE PROTECTION
Section: 07280-Water Resistive Barriers****REPORT HOLDER:****ENVIRONMENTALLY SAFE PRODUCTS
313 WEST GOLDEN LANE
NEW OXFORD, PENNSYLVANIA 17350
(800) 289-5693
www.low-e.com****EVALUATION SUBJECT:****ESP LOW-E HOUSEWRAP****1.0 EVALUATION SCOPE****Compliance with the following codes:**

- **2009 International Building Code® (2009 IBC)**
- **2009 International Residential Code® (2009 IRC)**
- **2006 International Building Code® (2006 IBC)**
- **2006 International Residential Code® (2006 IRC)**

Properties evaluated:

- **Water resistance**
- **Vapor permeability**
- **Surface burning characteristics**

2.0 USES

ESP Low-E Housewrap is used as a water-resistive barrier on the exterior side of exterior walls of buildings of Type V construction under the IBC and construction permitted under the IRC. The product is an alternative to the water-resistive barrier specified in IBC Section 1404.2 and IRC Section 703.2. The product is also considered equivalent to a 60-minute Grade D building paper as described in IBC Section 2510.6 and IRC Section 703.6.3.

3.0 DESCRIPTION

ESP Low-E Housewrap is comprised of a nominally 3/16-inch-thick [0.22 inch actual (5.6 mm) closed cell polyethylene core having a 1.5-pound-per-cubic-foot (24.0 kg/m³) nominal density, flame laminated to a 99 percent pure aluminum foil facer which is then perforated. ESP Low-E Housewrap weighs approximately 0.64 ounce per square foot (195 g/m²). ESP Low-E Housewrap is packaged in rolls, available in widths of 4, 5 and 6 feet (1219, 1524 and 1829 mm). ESP Low-E Housewrap has a flame-spread index of not more than 25 and a smoke

developed index of not more than 450 when tested in accordance with ASTM E84.

4.0 INSTALLATION

ESP Low-E Housewrap is installed over exterior wall sheathing prior to or after the installation of windows and/or doors. If doors and windows have been installed, the ESP Low-E Housewrap must be trimmed as close to the window or door opening as possible and sealed with approved adhesive tape. The Low-E Housewrap roll is placed approximately 6 inches (152 mm) from the start of a corner and is fastened to sheathing with corrosion-resistant staples having minimum 1-inch-wide (25.4 mm) crowns, corrosion-resistant nails having minimum 3/8-inch diameter (9.5 mm) heads or corrosion-resistant nails having minimum 1-inch-diameter (25.4 mm) plastic heads. Fasteners must be spaced a maximum of 16 inches (406 mm) on center both vertically and horizontally.

The Low-E Housewrap must be installed with the foil facing visible from the exterior. Product overlaps are 2.5 inches (63 mm) for horizontal seams. Upper courses are to overlap lower courses in a shingle-like manner. Horizontal seams must be taped with approved foil tape. Vertical overlaps must be a minimum of 6 inches (152 mm).

When Low-E Housewrap is used over foam sheathing, it must be attached with roofing nails or approved fasteners whose length exceeds the foam thickness by a minimum of 1/2 inch (12.7 mm). When used over wood based sheathing in an exterior stucco application, the Low-E Housewrap must be applied over two layers of Grade D water-resistive barrier with a 60-minute water resistive rating, applied over sheathing in accordance with IBC Section 2510.6 or IRC Section R 703.6.3.

5.0 CONDITIONS OF USE

The Low-E Housewrap described in this report complies with, or is a suitable alternative to what is specified in those codes listed in Section 1.0 of this report, subject to the following conditions:

- 5.1** Low-E Housewrap must be manufactured, identified and installed in accordance with this report and the manufacturers published installation instructions. In the event of a conflict between the manufacturers published installation instructions and this report, this report governs.
- 5.2** The interior of the building must be separated from the Low-E Housewrap using an approved thermal barrier in accordance with IBC Section 2603.4, or Section R316.4 of the 2009 IRC or Section R314.4 of the 2006 IRC, as applicable.

5.3 Low-E Housewrap is manufactured in New Oxford, Pennsylvania, with inspections by Intertek Testing Services NA Ltd. (AA-690)

6.0 EVIDENCE SUBMITTED

- 6.1 Data in accordance with the ICC-ES Acceptance Criteria for Water Resistant Barriers (Ac308), dated October 2009
- 6.2 Reports of testing in accordance with ASTM E84.

7.0 IDENTIFICATION

ESP Low-E Housewrap is identified by a label attached to each roll which includes the manufacturer's address and phone numbers, traceability information, and the evaluation report number (ESP-3079). Labeling includes a statement noting the flame-spread index of 25 or less and the smoke-developed index of 450 or less and the name of the inspection agency (Intertek Testing Services NA Ltd.). "ESR-3079" is printed on each roll at regular intervals.

SOUTHWEST RESEARCH INSTITUTE®

6220 CULEBRA RD. 78238-5166 • P.O. DRAWER 28510 78228-0510 • SAN ANTONIO, TEXAS, USA • (210) 684-5111 • WWW.SWRI.ORG
CHEMISTRY AND CHEMICAL ENGINEERING DIVISION
FIRE TECHNOLOGY DEPARTMENT
WWW.FIRE.SWRI.ORG
FAX (210) 522-3377



FIRE PERFORMANCE EVALUATION OF 4PFNS, IN ACCORDANCE WITH THE 2006 EDITION OF NATIONAL FIRE PROTECTION ASSOCIATION 286, STANDARD METHODS OF FIRE TESTS FOR EVALUATING CONTRIBUTION OF WALL AND CEILING INTERIOR FINISH TO ROOM FIRE GROWTH

FINAL REPORT

Consisting of 13 Pages

SwRI Project No. 01.15216.01.215a

Test Date: August 17, 2010

Report Date: September 7, 2010

Prepared for:

Environmentally Safe Products, Inc.

313 W. Golden Lane

New Oxford, PA 17350

Prepared by:

David Ewan
Research Engineer
Material Flammability Section

Approved by:

Anthony L. Saucedo
Group Leader
Material Flammability Section

This report is for the information of the client. It may be used in its entirety for the purpose of securing product acceptance from duly constituted approval authorities. This report shall not be reproduced except in full, without the written approval of SwRI. Neither this report nor the name of the Institute shall be used in publicity or advertising.



HOUSTON, TEXAS (713) 977-1377 • WASHINGTON, DC (301) 801-0220

Client: Environmentally Safe Products, Inc.
Project No.: 01.15216.01.215a
Material ID:* 4PFNS
Trade Name:* House Wrap
Material Description:* Single-sided foil 5 × 5 scrim with perforated polyethylene foam core; A003.
Color:* Aluminum foil and green foam.

Table 1. Material Details.

Thickness*	Dimensions*	Density*	Substrate
0.220 in.	4 × 125 ft (roll)	1 pcf	½-in. Thick Gypsum Wallboard

Table 2. Material Preparation Dates.

Received	Prepared	Conditioned
July 27, 2010	August 16, 2010	July 29, 2010 – August 16, 2010

*Information provided by the Client.

Construction Details: Material was installed on the walls only. Installation began with the lower portion of the room being covered first. Material was secured using 1 5/8-in. coarse thread screws with 1¼-in. fender washers every 16 in. on perimeter and field. No vertical seams were present, with a continuous section of material, 4 ft high, attached to each wall. A second horizontal section was applied above the first, with a 2-in. overlap, completing the 8-ft room height with another continuous section. Aluminum tape, 3 in. width, was used to join the two sections at the horizontal seam.

The test room and building were at approximately 71 °F and 75% relative humidity at the start of the test. A summary of the test results is given in Table 3 below. Selected photographic documentation is provided in Figures 1 through 4, and visual observations can be found in Table 4. The test results are summarized in Appendix A.

Table 3. Summary of Test Results and Flashover Limits.

Material ID	Maximum Heat Release Rate (Total)	Total Heat Flux to the Floor	Maximum Average Upper Layer Temperature	Flames Exiting Doorway?	Auto-Ignition of Paper Target?
4PFNS	322 kW	7.9 kW/m ²	468 °C	No	No
Flashover Limits Per Section 1.4.2 of NFPA 286	1,000 kW	20 kW/m ²	600 °C	Not Allowed	Not Allowed

RESIDENTIAL ENERGY EFFICIENCY

SECTION 401 GENERAL

401.1 Scope. This chapter applies to residential buildings.

401.2 Compliance. Projects shall comply with Sections 401, 402.4, 402.5, and 403.1, 403.2.2, 403.2.3. and 403.3 through 403.9 (referred to as the mandatory provisions) and either:

1. Sections 402.1 through 402.3, 403.2.1 and 404.1 (prescriptive); or
2. Section 405 (performance)

401.3 Certificate. A permanent certificate shall be posted on or in the electrical distribution panel. The certificate shall not cover or obstruct the visibility of the circuit directory label, service disconnect label or other required labels. The certificate shall be completed by the builder or registered design professional. The certificate shall list the predominant *R*-values of insulation installed in or on ceiling/roof, walls, foundation (slab, *basement wall*, crawlspace wall and/or floor) and ducts outside conditioned spaces; *U*-factors for fenestration and the solar heat gain coefficient (SHGC) of fenestration. Where there is more than one value for each component, the certificate shall list the value covering the largest area. The certificate shall list the types and efficien-

cies of heating, cooling and service water heating equipment. Where a gas-fired unvented room heater, electric furnace, or baseboard electric heater is installed in the residence, the certificate shall list “gas-fired unvented room heater”, “electric furnace” or “baseboard electric heater”, as appropriate. An efficiency shall not be listed for gas-fired unvented room heaters, electric furnaces or electric baseboard heaters.

SECTION 402 BUILDING THERMAL ENVELOPE

402.1 General (Prescriptive)

402.1.1 Insulation and fenestration criteria. The *building thermal envelope* shall meet the requirements of Table 402.1.1 based in the climate *zone* specified in Chapter 3

402.1.2 R-value computation. Insulation material used in layers such as framing cavity insulation and insulating sheathing, shall be summed to compute the component *R*-value. The manufacturer’s settled *R*-value shall be used for blown insulation. Computed *R*-values shall not include an *R*-value for other building materials or air films.

CLIMATE ZONE	FENESTRATION U-FACTOR ^b	SKYLIGHT ^o U-FACTOR	GLAZED FENESTRATION SHGC ^{b,e}	CEILING R-VALUE	WOOD FRAME WALL R-VALUE	MASS WALL R-VALUE ^j	FLOOR R-VALUE	BASEMENT ^c WALL R-VALUE	SLAB ^d R-VALUE & DEPTH	CRAWL SPACE ^c WALL R-VALUE
1	1.2	0.75	0.30	30	13	3/4	13	0	0	0
2	0.65 ⁱ	0.75	0.30	30	13	4/6	13	0	0	0
3	0.50 ⁱ	0.65	0.30	30	13	5/8	19	5/13 ^f	0	5/13
4 except Marine	0.35	0.60	NR	38	13	5/10	19	10/13	10, 2 ft	10/13
5 and Marine 4	0.35	0.60	NR	38	20 or 13+5 ^h	13/17	30 ^g	10/13	10, 2 ft	10/13
6	0.35	0.60	NR	49	20 or 13+5 ^h	15/19	30 ^g	15/19	10, 4 ft	10/13
7 and 8	0.35	0.60	NR	49	21	19/21	38 ^g	15/19	10, 4 ft	10/13

For SI: 1 foot= 304.8 mm.

- a. *R*-values are minimums. *U*-factors and SHGC are maximums. R-19 batts compressed into a nominal 2 x 6 framing cavity such that the R-value is reduced by R-1 or more shall be marked with the compressed batt *R*-value in addition to the full thickness *R*-value.
- b. The fenestration *U*-factor column excludes skylights. The SHGC column applies to all glazed fenestration.
- c. “15/19” means R-15 continuous insulated sheathing on the interior or exterior of the home or R-19 cavity insulation at the interior of the basement wall. “15/19” shall be permitted to be met with R-13 cavity insulation on the interior of the basement wall plus R-5 continuous insulated sheathing on the interior or exterior of the home. “10/13” means R-10 continuous insulated sheathing on the interior or exterior of the home or R-13 cavity insulation at the interior of the basement wall.
- d. R-5 shall be added to the required slab edge *R*-values for heated slabs. Insulation depth shall be the depth of the footing or 2 feet, whichever is less in Zones 1 through 3 for heated slabs.
- e. There are no SHGC requirements in the Marine Zone.
- f. Basement wall insulation is not required in warm-humid locations as defined by Figure 301.1 and Table 301.1.
- g. Or insulation sufficient to fill the framing cavity. R-19 minimum.
- h. “13+5” means R-13 cavity insulation plus R-5 insulated sheathing. If structural sheathing covers 25 percent or less of the exterior, insulating sheathing is not required where structural sheathing is used. If structural sheathing covers more than 25 percent of exterior, structural sheathing shall be supplemented with insulated sheathing of at least R-2.
- i. The second *R*-value applies when more than half the insulation is on the interior of the mass wall.
- j. For impact rated fenestration complying with Section R301.2.1.2 of the *International Residential Code* or Section 1608.1.2 of the *International Building Code*, the maximum *U*-factor shall be 0.75 in Zone 2 and 0.65 in Zone 3.

**TABLE 402.1.3
EQUIVALENT U-FACTORS^a**

CLIMATE ZONE	FENESTRATION U-FACTOR ^b	SKYLIGHT ^b U-FACTOR	CEILING U-FACTOR	FRAME WALL U-FACTOR	MASS WALL U-FACTOR ^b	FLOOR U-FACTOR	BASEMENT WALL U-FACTOR ^d	CRAWL SPACE WALL U-FACTOR ^c
1	1.20	0.75	0.035	0.082	0.197	0.064	0.360	0.477
2	0.65 ^d	0.75	0.035	0.082	0.165	0.064	0.360	0.477
3	0.50 ^d	0.65	0.035	0.082	0.141	0.047	0.091	0.136
4 except Marine	0.35	0.60	0.030	0.082	0.141	0.047	0.059	0.065
5 and Marine 4	0.35	0.60	0.030	0.057	0.082	0.033	0.059	0.065
6	0.35	0.60	0.026	0.057	0.060	0.033	0.050	0.065
7 and 8	0.35	0.60	0.026	0.057	0.057	0.028	0.050	0.065

- a. Nonfenestration *U*-factors shall be obtained from measurement, calculation or an approved source.
- b. When more than half the insulation is on the interior the mass wall *U*-factors shall be a maximum of 0.17 In Zone 1, 0.14 in Zone 2, 0.12 in Zone 3, 0.10 in Zone 4 except Marine, and the same as the frame wall *U*-factor in Marine Zone 4 and Zones 5 through 8.
- c. Basement wall *U*-factor of 0.360 in warm-humid locations as defined by Figure 301.1 and Table 301.2.
- d. Foundation *U*-factor requirements shown in Table 402.1.3 include wall construction and interior air films but exclude soil conductivity and exterior air films. *U*-factors for determining code compliance in accordance with Section 402.1.4 (total UA alternative) of Section 405 (Simulated Performance Alternative) shall be modified to include soil conductivity and exterior air films.

402.1.3 *U*-factor alternative. An assembly with a *U*-factor equal to or less than that specified in Table 402.1.3 shall be permitted as an alternative to the *R*-value in Table 402.1.1.

402.1.4 Total UA alternative. If the total *building thermal envelope UA* (sum of *U*-factor times assembly area) is less than or equal to the total UA resulting from using the *U*-factors in Table 402.1.3 (multiplied by the same assembly area as in the proposed building), the building shall be considered in compliance with Table 402.1.1. The UA calculation shall be done using a method consistent with the *ASHRAE Handbook of Fundamentals* and shall include the thermal bridging effects of framing materials. The SHGC requirements shall be met in addition to UA compliance.

402.2 Specific insulation requirements (Prescriptive).

402.2.1 Ceilings with attic spaces. When Section 402.1.1 would require R-38 in the ceiling, R-30 shall be deemed to satisfy the requirement for R-38 wherever the full height of uncompressed R-30 insulation extends over the wall top plate at the eaves. Similarly, R-38 shall be deemed to satisfy the requirement for R-49 wherever the full height of uncompressed R-38 insulation extends over the wall top plate at the eaves. This reduction shall not apply to the *U*-factor alternative approach in Section 402.1.3 and the total UA alternative in Section 402.1.4.

402.2.2 Ceilings without attic spaces. Where Section 402.1.1 would require insulation levels above R-30 and the design of the roof/ceiling assembly does not allow sufficient space for the required insulation, the minimum required insulation for such roof/ceiling assemblies shall be R-30. This reduction of insulation from the requirements of Section 402.1.1 shall be limited to 500 square feet (46 m²) or 20

percent of the total insulated ceiling area, whichever is less. This reduction shall not apply to the *U*-factor alternative approach in Section 402.1.3 and the total UA alternative in Section 402.1.4.

402.2.3 Access hatches and doors. Access doors from conditioned spaces to unconditioned spaces (e.g., attics and crawl spaces) shall be weatherstripped and insulated to a level equivalent to the insulation on the surrounding surfaces. Access shall be provided to all equipment that prevents damaging or compressing the insulation. A wood framed or equivalent baffle or retainer is required to be provided when loose fill insulation is installed, the purpose of which is to prevent the loose fill insulation from spilling into the living space when the attic access is opened, and to provide a permanent means of maintaining the installed *R*-value of the loose fill insulation.

402.2.4 Mass walls. Mass walls for the purposes of this chapter shall be considered above-grade walls of concrete block, concrete, insulated concrete form (ICF), masonry cavity, brick (other than brick veneer), earth (adobe, compressed earth block, rammed earth) and solid timber/logs.

402.2.5 Steel-frame ceilings, walls, and floors. Steel-frame ceilings, walls and floors shall meet the insulation requirements of Table 402.2.5 or shall meet the *U*-factor requirements in Table 402.1.3. The calculation of the *U*-factor for a steel-frame envelope assembly shall use a series-parallel path calculation method.

Exception: In Climate Zones 1 and 2, the continuous insulation requirements in Table 402.2.4 shall be permitted to be reduced to R-3 for steel frame wall assemblies with studs spaced at 24 inches (610 mm) on center.

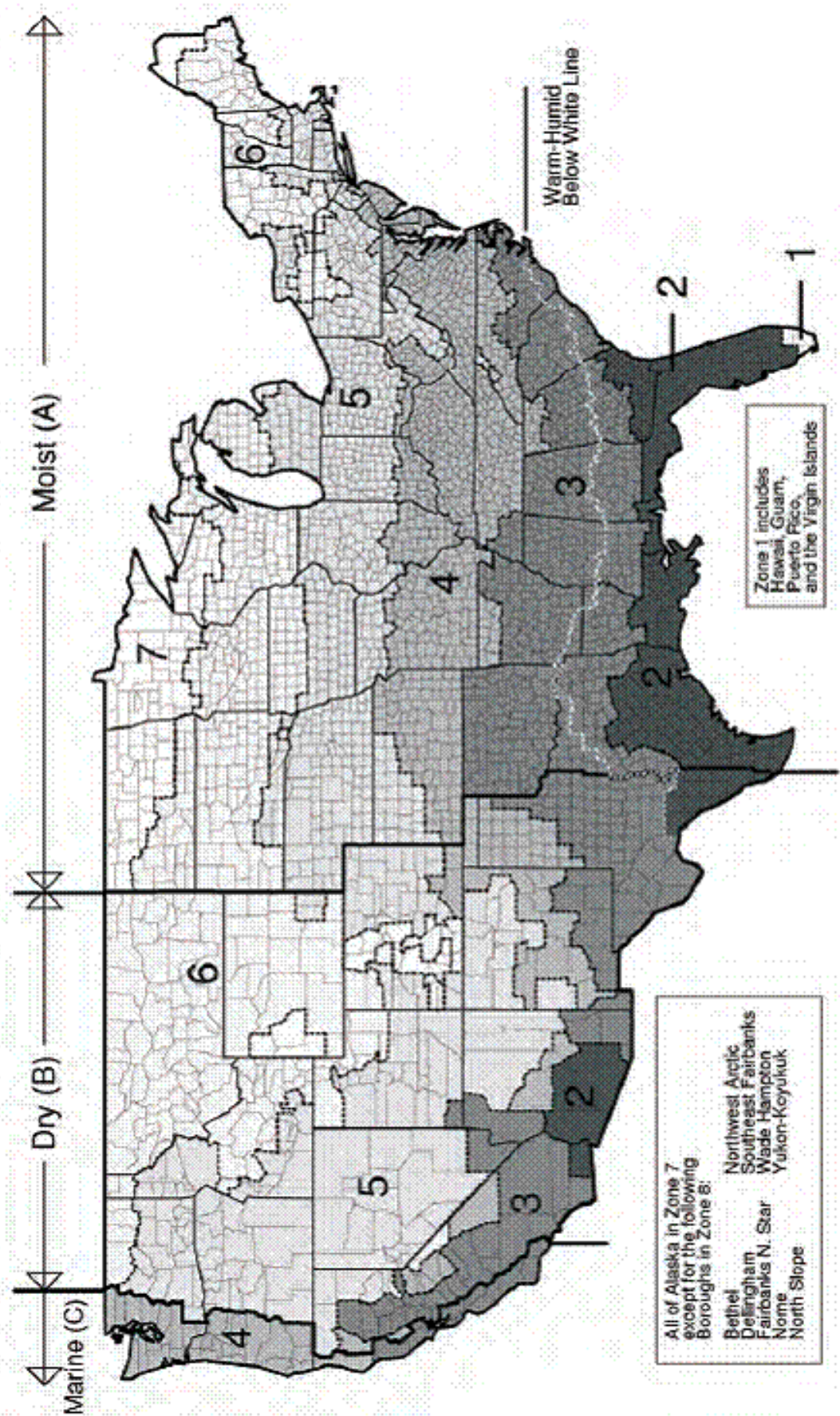

FIGURE 301.1
CLIMATE ZONES



Evaluation of Thermal Resistance of a Building Envelope Assembly

The following evaluation is based on established guidelines published by ASHRAE along with results obtained using ASTM test methods and published procedures. The U-value for the assembly is based on the parallel-path method.

Description of the Building Assembly

Nominal 2x4 wood-frame wall constructed 16 in. OC. A diagram is attached that shows the sequence of elements in the assembly. Double top plate construction has been assumed. Both summer and winter conditions have been evaluated.

Summer Temperatures: Outside air 100 °F (Inside air 70 °F)
 Winter Temperatures: Outside air 40 °F (Inside air 70 °F)

Framing factor (fraction of wall area that is wood): 0.136

The low-emittance material forming the reflective air space has emittance 0.03.
 R-value units are ft²·h·°F/Btu. U-value units are Btu/ft²·h·°F.

Element	Cavity Path		Framing Path	
	Summer	Winter	Summer	Winter
Outside air film	0.25	0.17	0.25	0.17
Siding	0.61	0.61	0.61	0.61
0.375-in. reflective air space	1.89	2.09	1.89	2.09
Low-e Housewrap	1.03	1.03	1.03	1.03
0.5-in. OSB	0.66	0.66	0.66	0.66
R 15 batt insulation	15.00	15.00	-	-
Wood framing	-	-	4.38	4.38
0.5-in. gypsum	0.45	0.45	0.45	0.45
Inside air film	<u>0.68</u>	<u>0.68</u>	<u>0.68</u>	<u>0.68</u>
Path Total	20.57	20.69	9.95	10.07
U-value (air-to-air)	0.056	0.055		

The calculations summarized in the above table indicate the assembly U-value of 0.056 Btu/ft²·h·°F to be appropriate for both summer and winter conditions.

David W. Yarbrough, PhD, PE
 President
 September 10, 2009

References:

ASHRAE Handbook of Fundamentals (2009) Chapter 25
 American Society for Testing and Materials STP 1116, pp 24-43.

R&D Services, Inc.

P.O. Box 2400, Cookeville, Tennessee, 38502-2400
 R.S. Graves: 931-372-8871, E-mail: ron@rdservices.com D.W. Yarbrough: 931-526-3348, E-mail: dave@rdservices.com
 Fax: 931-525-3896 Website: http://www.rdservices.com



Calculated R-Value and U-Value for a Wall Assembly with a Brick Façade and Low-e Insulation

A parallel-path calculation has been performed to evaluate the U-value for a wall assembly consisting of a brick façade, low-e insulation installed to produce a reflective air space, and R 15 wall-cavity insulation. A U-value of 0.050 Btu/ft²h°F was obtained for winter conditions and 0.051 for summer conditions. Calculations were based on outside air temperature of 100 °F in the summer and 40 °F in the winter with interior temperature 70 °F in both cases. The difference between winter and summer values is related to the exterior air film resistance and the reflective air space. The wood-frame region in the wall assembly was taken to be nominal 2x4 in. construction with vertical members placed 16 in. OC with double top plates. The resulting heat flow path fractions are 0.864 for the cavity path and 0.136 for the frame path. The following tabulations summarize the calculations.

Winter Condition

Element	R-value (ft ² h°F/Btu)		Reference
	Cavity Path	Frame Path	
Exterior air film	0.17	0.17	1
Brick Façade	0.74	0.74	2
Reflective Air Space	3.716	3.716	3
Low-e insulation	1.03	1.03	4
½-in. OSB	0.66	0.66	1
Fiberglass Batt	15.00	-	4
Framing	-	4.38	1
½-in. gypsum	0.45	0.45	1
Interior air film	0.68	0.68	1
Total	22.446	11.826	

$$U\text{-Value} = 0.864/22.446 + 0.136/11.826 = 0.050 \text{ Btu/ft}^2\text{h}^\circ\text{F}$$

R&D Services, Inc.

P.O. Box 2400, Cookeville, Tennessee, 38502-2400
 R.S. Graves: 931-372-8871, E-mail: ron@rdservices.com • D.W. Yarbrough: 931-526-3348, E-mail: dave@rdservices.com
 Fax: 931-525-3896 • Website: <http://www.rdservices.com>

Summer Condition

Element	R-value (ft ² h°F/Btu)		Reference
	Cavity Path	Frame Path	
Exterior air film	0.25	0.25	1
Brick Façade	0.74	0.74	2
Reflective Air Space (0.75 in.)	3.440	3.440	3
Low-e insulation	1.03	1.03	4
½-in. OSB	0.66	0.66	1
Fiberglass Batt	15.00	-	5
Framing	-	4.38	1
½-in. gypsum	0.45	0.45	1
Interior air film	0.68	0.68	1
Total	22.250	11.630	

$$U\text{-Value} = 0.864/22.250 + 0.136/11.630 = 0.051 \text{ Btu/ft}^2\text{h}^\circ\text{F}$$



David W. Yarbrough, PhD, PE

November 14, 2009

References

- (1) Chapter 26 in the 2009 ASHRAE Handbook of Fundamentals.
- (2) Valore et al., ORNL/Sub/86-22020/1, Oak Ridge National Laboratory (1988).
- (3) Desjarlais and Yarbrough, ASTM STP 1116 (1991) pp 24-43.
- (4) R&D Services, Inc., C 518 Test Report.
- (5) Manufacturer's Label Value.

R&D Services, Inc.

P.O. Box 2400, Cookeville, Tennessee, 38502-2400
R.S. Graves: 931-372-8871, E-mail: ron@rdservices.com D.W. Yarbrough: 931-526-3348, E-mail: dave@rdservices.com
Fax: 931-525-3896 Website: <http://www.rdservices.com>



Calculated R-Value and U-Value for a Wall Assembly with a Cultured Stone Façade and Low-e Insulation

A parallel-path calculation has been performed to evaluate the U-value for a wall assembly consisting of a cultured-stone façade, low-e insulation, and R 15 wall-cavity insulation. A U-value of 0.063 Btu/ft²·h·°F was obtained for both winter and summer conditions. Calculations were based on outside air temperature of 100 °F in the summer and 40 °F in the winter with interior temperature 70 °F in both cases. Since there are no enclosed reflective air spaces in the assembly, the difference between winter and summer values is related to the exterior air film resistance. The wood-frame region in the wall assembly was taken to be nominal 2x4 in. construction with vertical members placed 16 in. OC with double top plates. The resulting heat flow path fractions are 0.864 for the cavity path and 0.136 for the frame path. The following tabulations summarize the calculations.

Winter Condition

<u>Element</u>	<u>R-value (ft²·h·°F/Btu)</u>		<u>Reference</u>
	<u>Cavity Path</u>	<u>Frame Path</u>	
Exterior air film	0.17	0.17	1
Stone Façade (1.75 in.)	0.61	0.61	2
Low-e insulation	1.03	1.03	3
½-in. OSB	0.66	0.66	1
Fiberglass Batt	15.00	-	4
Framing	-	4.38	1
½-in. gypsum	0.45	0.45	1
Interior air film	0.68	0.68	1
Total	18.60	7.98	

$$U\text{-Value} = 0.864/18.60 + 0.136/7.98 = 0.063 \text{ Btu/ft}^2\cdot\text{h}\cdot\text{°F}$$

R&D Services, Inc.

P.O. Box 2400, Cookeville, Tennessee, 38502-2400
 R.S. Graves: 931-372-8871, E-mail: ron@rdservices.com • D.W. Yarbrough: 931-526-3348, E-mail: dave@rdservices.com
 Fax: 931-525-3896 • Website: <http://www.rdservices.com>

Summer Condition

<u>Element</u>	<u>R-value (ft²h²F/Btu)</u>		<u>Reference</u>
	<u>Cavity Path</u>	<u>Frame Path</u>	
Exterior air film	0.25	0.25	1
Stone Façade (1.75 in.)	0.61	0.61	2
Low-e insulation	1.03	1.03	3
½-in. OSB	0.66	0.66	1
Fiberglass Batt	15.00	-	4
Framing	-	4.38	1
½-in. gypsum	0.45	0.45	1
Interior air film	0.68	0.68	1
Total	18.68	8.06	

$$U\text{-Value} = 0.864/18.68 + 0.136/8.06 = 0.063 \text{ Btu/ft}^2\text{h}^2\text{F}$$



David W. Yarbrough, PhD, PE
November 14, 2009

References

- (1) Chapter 26 in the 2009 ASHRAE Handbook of Fundamentals.
- (2) Technical Bulletin, Lowe's Building Supplies.
- (3) R&D Services, Inc, C 518 Test Report
- (4) Manufacturer's Label Value

R&D Services, Inc.

P.O. Box 2400, Cookeville, Tennessee, 38502-2400
R.S. Graves: 931-372-8871, E-mail: ron@rdservices.com D.W. Yarbrough: 931-526-3348, E-mail: dave@rdservices.com
Fax: 931-525-3896 Website: <http://www.rdservices.com>

Low-E Housewrap™ Installation Sheet

Installation Method (Existing Walls)

1. Low-E Housewrap is installed over exterior wall sheathing, make sure reflective side faces out.
2. If product has foil flange make sure foil flange side of roll faces down.
3. Determine width of HouseWrap being used (4', 5', 6') for initial wrap (lowest point of wall surface)
4. Measure from sill plate up the wall, mark wall at level of determined width less 1" i.e. 5' HouseWrap Mark at 59"
5. Snap chalkline around perimeter
6. Starting at the corner of the preferred exterior wall unroll Low-E Housewrap™ in a horizontal manner. Fasten using corrosion resistant staples having minimum 1" wide crown, corrosion resistant nails having minimum 3/8" heads or corrosion resistant nails having minimum 1" diameter plastic heads. Fasteners to be spaced a maximum of 16" both vertically and horizontally.
7. If rolling Low-E Housewrap™ over door and window openings. (see pg. 6 for framed opening instructions). If windows and doors have been set, trim Low-E HouseWrap™ as close to window or door opening as possible and perform detailing as per door / window manufacturer and or code standards.
8. The bottom side of the Low-E Housewrap™ should extend over sill plate by minimum 1".
9. When applying second horizontal run of Low-E Housewrap™, butt foam ends together allowing foil flange to overlap 2". Make certain foil flange is to the outside to ensure water drainage plane downward.
10. Tape all vertical and horizontal flange seam areas with foil tape.
11. Continue method until Low-E Housewrap™ covers both top plates.
12. Use foil tape to repair areas that have been torn or compromised. (See page 7)
13. **Foil is a conductor of electricity. Use extreme caution when working with Low-E Housewrap™ around power lines, wiring and electrical devices.**

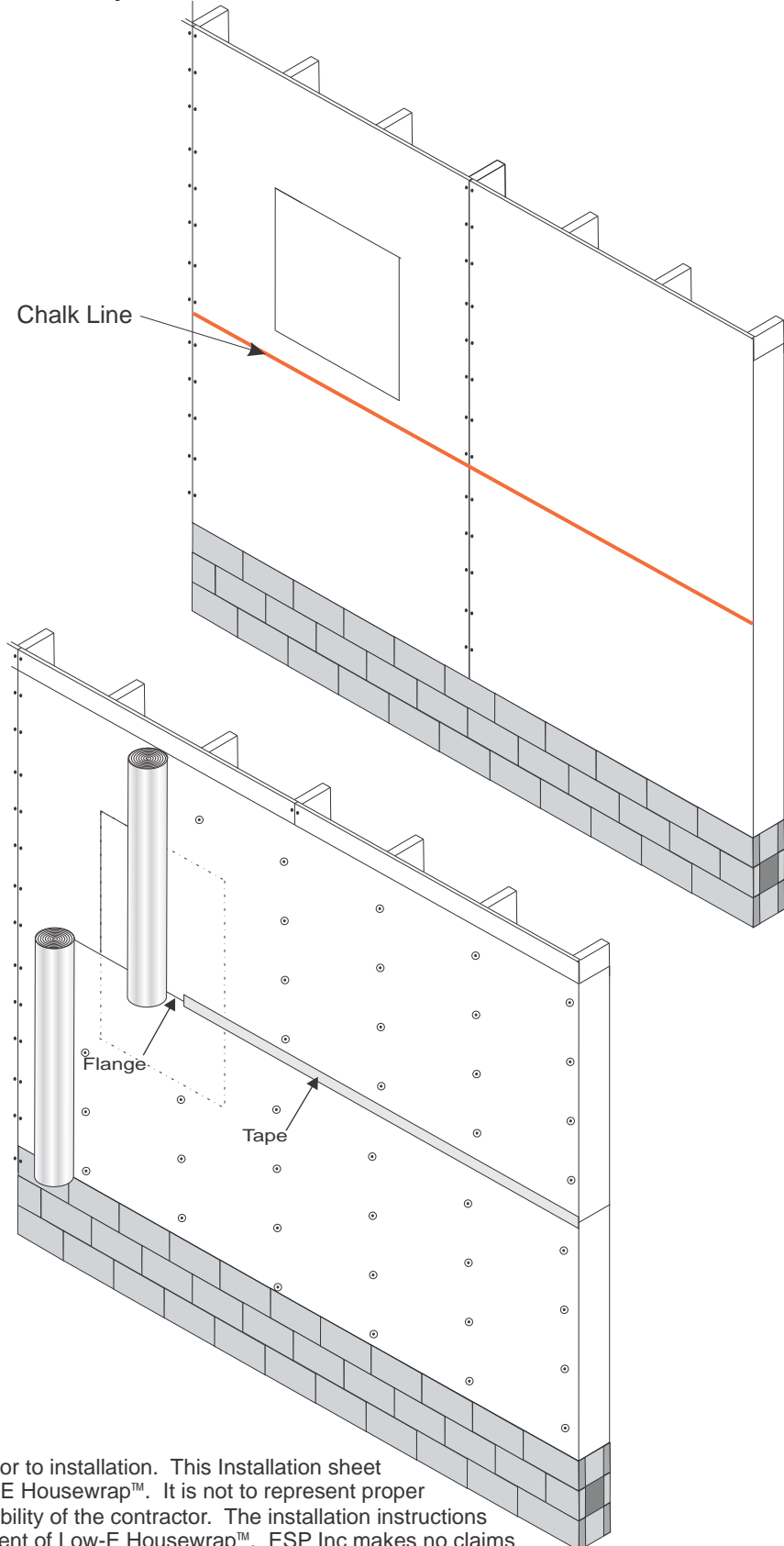

Suggested products for this application:

Low-E Housewrap™ 4PFNS,5PFNT,4PMPS,5PMPT

Low-E Foil Tape T0002

Check with your building code official for compliance prior to installation. This Installation sheet is intended to illustrate the intended area of use of Low-E Housewrap™. It is not to represent proper construction techniques which is ultimately the responsibility of the contractor. The installation instructions are recommendations showing the location and placement of Low-E Housewrap™. ESP Inc makes no claims that the above stated installation instructions are universally accurate.

Low-E Housewrap™ Installation Sheet

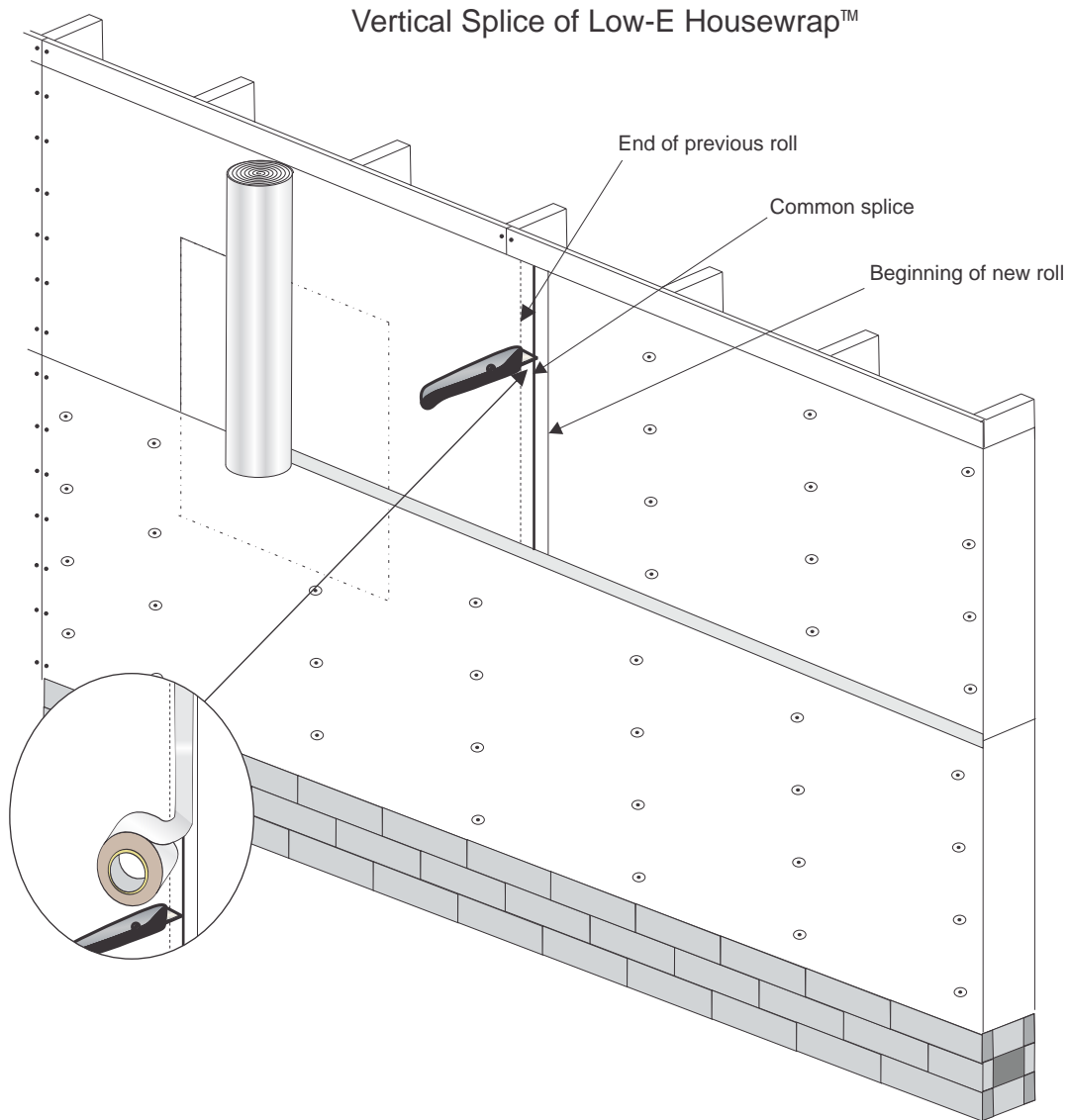

1. When coming to the end of existing roll in use, leave up to 12 inches of product unattached to wall system.
2. Remove new roll from packaging
3. Unroll Low-E Housewrap™ to desired area making sure that product is plumb and square with housewrap already in place and also overlap material past the end of previous material by approx 8 inches.
4. Locate center of overlapped materials and make common splice through both layers of material using utility knife.
5. Remove cut material from end of previous roll and start of new roll
6. Apply Low-E Tape over common splice, then continue installing Low-E Housewrap™ as described in Figure 1
7. If vertical splice is not performed product must overlap by minimum of 6"

Check with your building code official for compliance prior to installation. This Installation sheet is intended to illustrate the intended area of use of Low-E Housewrap™. It is not to represent proper construction techniques which is ultimately the responsibility of the contractor. The installation instructions are recommendations showing the location and placement of Low-E Housewrap™. ESP Inc makes no claims that the above stated installation instructions are universally accurate.

Low-E Housewrap™ Installation Sheet

Framed Openings

When installing Low-E Housewrap™ over the exterior of structure be sure to run product horizontally over entire wall including framed openings. (please refer to page 5 for more detailed instructions)

Once Low-E Housewrap™ has been securely fastened to exterior sheathing make cuts as shown in Figure 2.

Try not to cut past exterior side of framed opening (exception for top of framed opening) but in the event that occurs use Low-E foil tape to repair area that was compromised.

1. An additional flap should be cut above the top exterior side of framed opening for the installation of head flashing.

2. Bend flap away from wall to allow installation of window and flashing

3. Apply window and head flashing

4. Reset Low-E Housewrap™ and tape seams

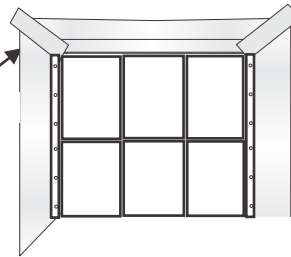
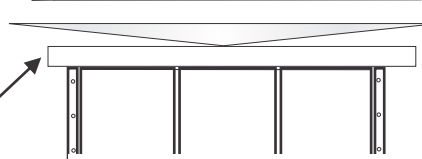
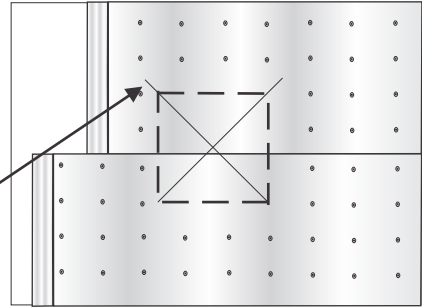

Once side and bottom flaps have been cut, bend these flaps toward the interior of structure using staples or adhesive to attach Low-E housewrap™ to the face of the jamb.

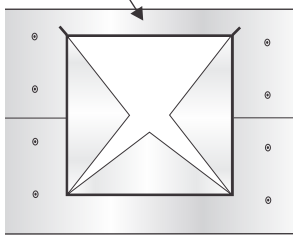

Remove excess material by using inside face of stud as cutting guide

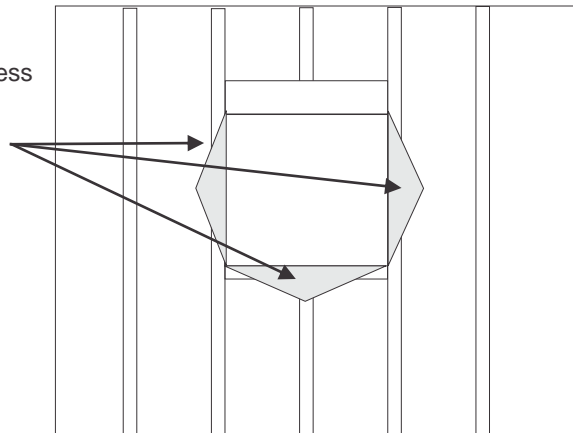

Follow door and window manufacturers instructions for flashing and installation relating to their respective products.

Check with your building code official for compliance prior to installation. This Installation sheet is intended to illustrate the intended area of use of Low-E Housewrap™. It is not to represent proper construction techniques which is ultimately the responsibility of the contractor. The installation instructions are recommendations showing the location and placement of Low-E Housewrap™. ESP Inc makes no claims that the above stated installation instructions are universally accurate.

Low-E Housewrap™ Installation Sheet

Penetration Installation Diagrams

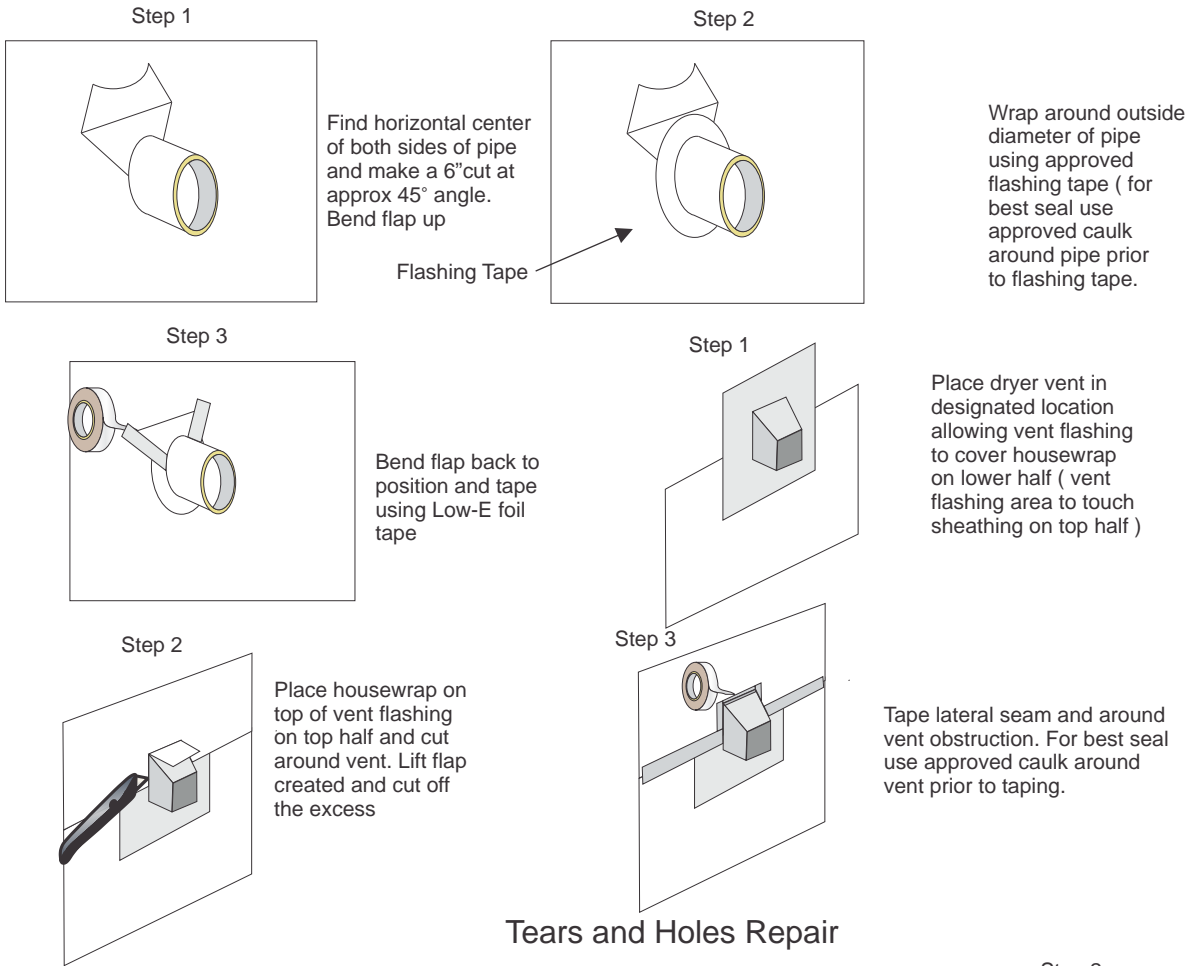

Tears and Holes Repair

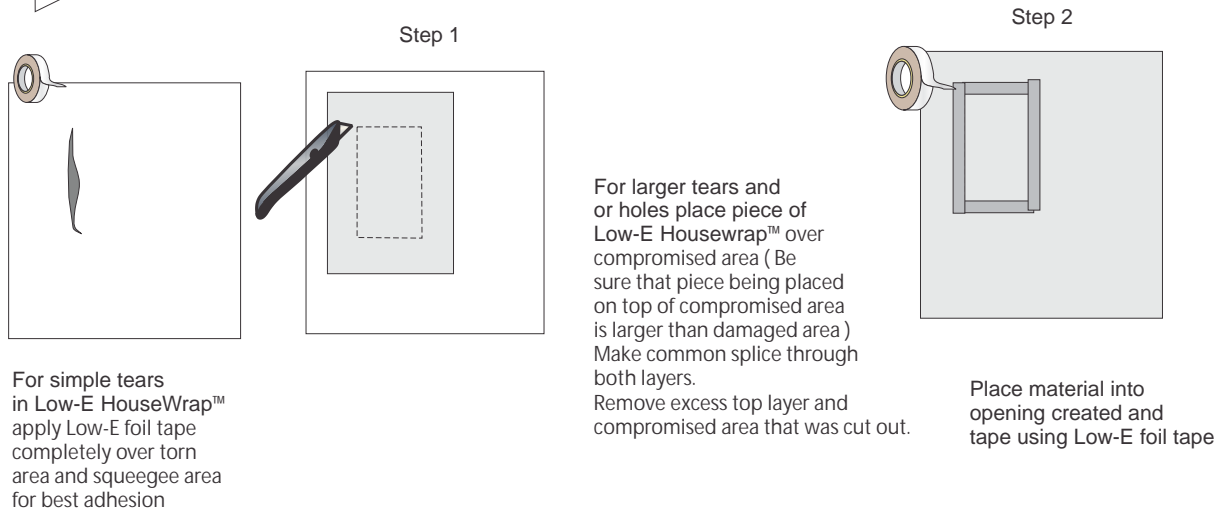

Check with your building code official for compliance prior to installation. This Installation sheet is intended to illustrate the intended area of use of Low-E Housewrap™. It is not to represent proper construction techniques which is ultimately the responsibility of the contractor. The installation instructions are recommendations showing the location and placement of Low-E Housewrap™. ESP Inc makes no claims that the above stated installation instructions are universally accurate.

Low-E Housewrap™ Installation Sheet

Tilt Wall Installation Method

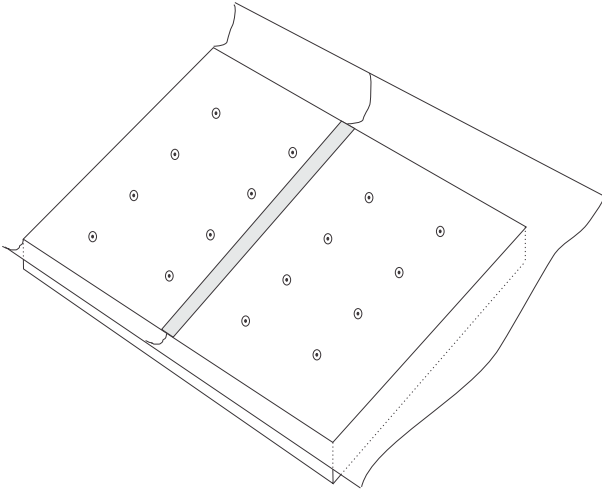

Place Low-E Housewrap™ on wall system leaving excess material approx 12" on both sides and bottom.
 (Areas where common splice will be made once wall is tilted up do not need any fasteners at this time)

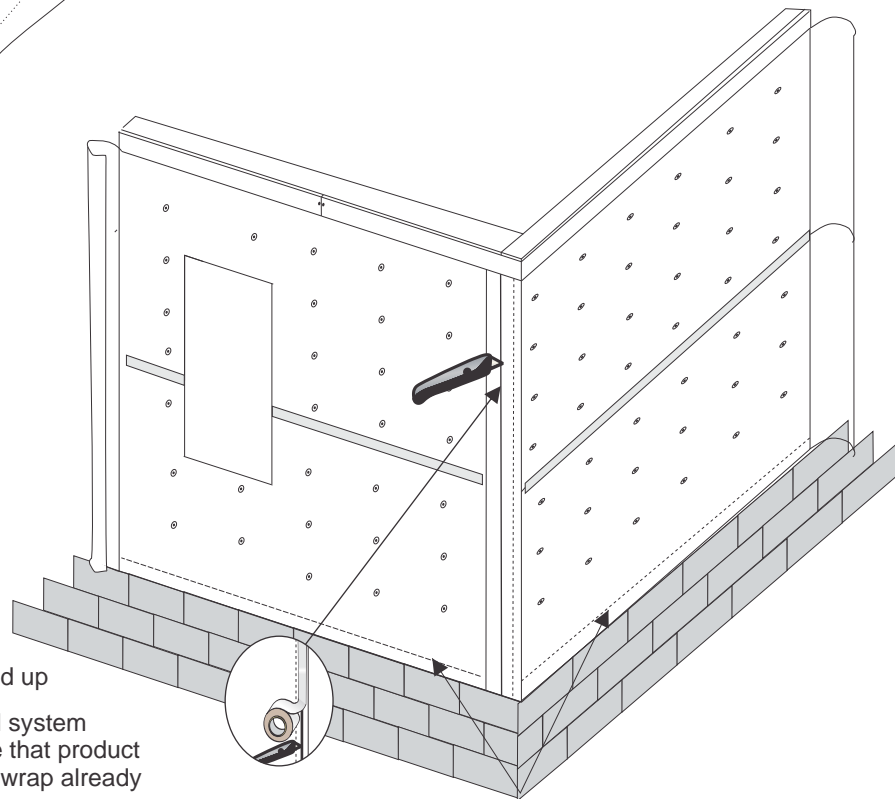

Once wall system has been tilted up

1. Overlap excess material on wall system that's been adjoined. Make sure that product is plumb and square with housewrap already in place.
2. Locate center of overlapped materials and make common splice through both layers of material using utility knife.
3. Remove cut material from both sides of previously installed material
4. Use additional fasteners in as needed.
5. Apply Low-E Tape over common splice.

Make sure Low-E Housewrap™ overlaps bottom plate

Check with your building code official for compliance prior to installation. This Installation sheet is intended to illustrate the intended area of use of Low-E Housewrap™. It is not to represent proper construction techniques which is ultimately the responsibility of the contractor. The installation instructions are recommendations showing the location and placement of Low-E Housewrap™. ESP Inc makes no claims that the above stated installation instructions are universally accurate.

